

LINEAR ACTUATOR



12/24V LINEAR ACTUATORS WITH SOLID PROTECTION AND PRECISE CONTROL.

- Built-in processor for precise control of hydraulic valves, accurate to 0.01"
- Compact design that allows for easy installation.
- Retrofit electronic control onto manual over hydraulic valves that don't have solenoids or coils for electric over hydraulic control, or to be used for a throttle actuator.
- 90 pounds of force over a 3" maximum stroke.
- Smart, precise CANbus control over J1939.
- Internal clutch for safety to enable freewheeling back to center position when the joystick is released or power is lost.
- High-speed processor safety mechanisms built in to protect the motor and clutch for extended life.
- A new custom engineered contactless sensor for feedback.
- Totally encapsulated electronics. Providing the most solid protection from vibration on extreme-duty off-highway equipment.



ELECTRICAL

Protection Types	Reverse polarity, over-voltage
Supply Voltage	9-30VDC

ENVIRONMENTAL

Operating Temperature	-40° C to +85° C
Storage Temperature	-50° C to +100° C
Protection Class	IP67

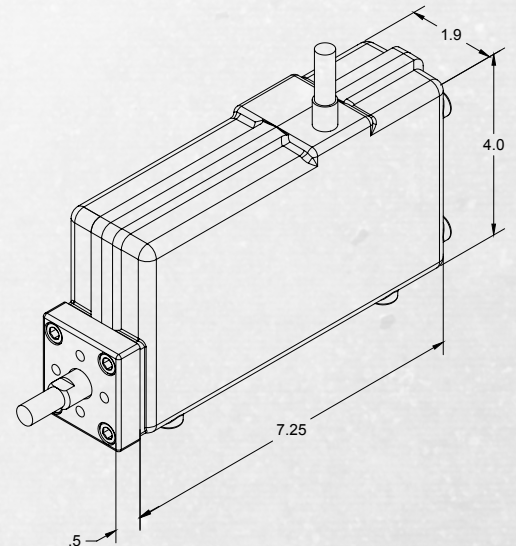

Tel. 309.291.0966 | www.AutonomouStuff.com | info@AutonomouStuff.com

