

Rugged Vehicle Safety Controller with Dual Emergency Stop Inputs and Outputs, USB, RS232, and CAN Integration Interfaces



FORT's Safe Remote Control System is a medium to long-range wireless controller designed from the ground up to enable the safe operation of remote and automated systems. It provides a rugged, ergonomic, and easy to understand controller with a flexible receiver that both implement FORT's proprietary SafetySense™ technology to ensure both consistent and reliable control.

1. Applications

- Control of remote, tele-operated, semi- or fully autonomous robotic systems where safety and usability are critical.
- Monitoring of fixed or mobile industrial systems requiring sophisticated control and reliable wireless emergency stop capabilities.
- Pan & tilt controls for security and surveillance.

2. Key Features (Vehicle Safety Controller – VSC)

- SafetySense™ Secure wireless communications with AES128 encryption and range of 1000+ ft
 - Frequency bands include 900 MHz, 2.4 GHz (other bands available)
 - AES256 encryption available upon request
- USB, RS-232 serial, and CAN bus support for flexible system integration options
- Hardware-based SafetySense™ implementation for high reliability, no single point of failure safety implementation
- Differential wired emergency stop input
- Master enable output for direct stop of motion control equipment
- 8 to 28 VDC power input
- USB configuration for programming and configuration
- Multiple connector options available
 - RP-SMA antenna connector
 - Mini-CPC 4 pin for USB
 - Mini-CPC 9 pin for Power, Estop I/O, RS232, and CAN interfaces
- IP66 (NEMA 4X) rated enclosure
- -20°C to 60°C operation
- ROS™ and C drivers available to accelerate system software development

3. SafetySense™ Technology

SafetySense™ Technology consists of major system-level technologies that work together to provide the integrator the ability to design systems with consistent and reliable remote operations.

While the receiver is monitoring the health of both remote and user computer, it contains dedicated hardware that is monitoring its internal health. Both firmware-based and independent hardware based watchdog timers monitor the functionality of the receiver firmware. The communication link to the remote is also monitored directly in hardware (independent of the firmware-based monitoring). Finally, the reference clock source, used by this custom hardware block, is monitored by a third independent timer to ensure that is operating within its specifications. A failure in any of these components causes the system to indicate an emergency stop situation.

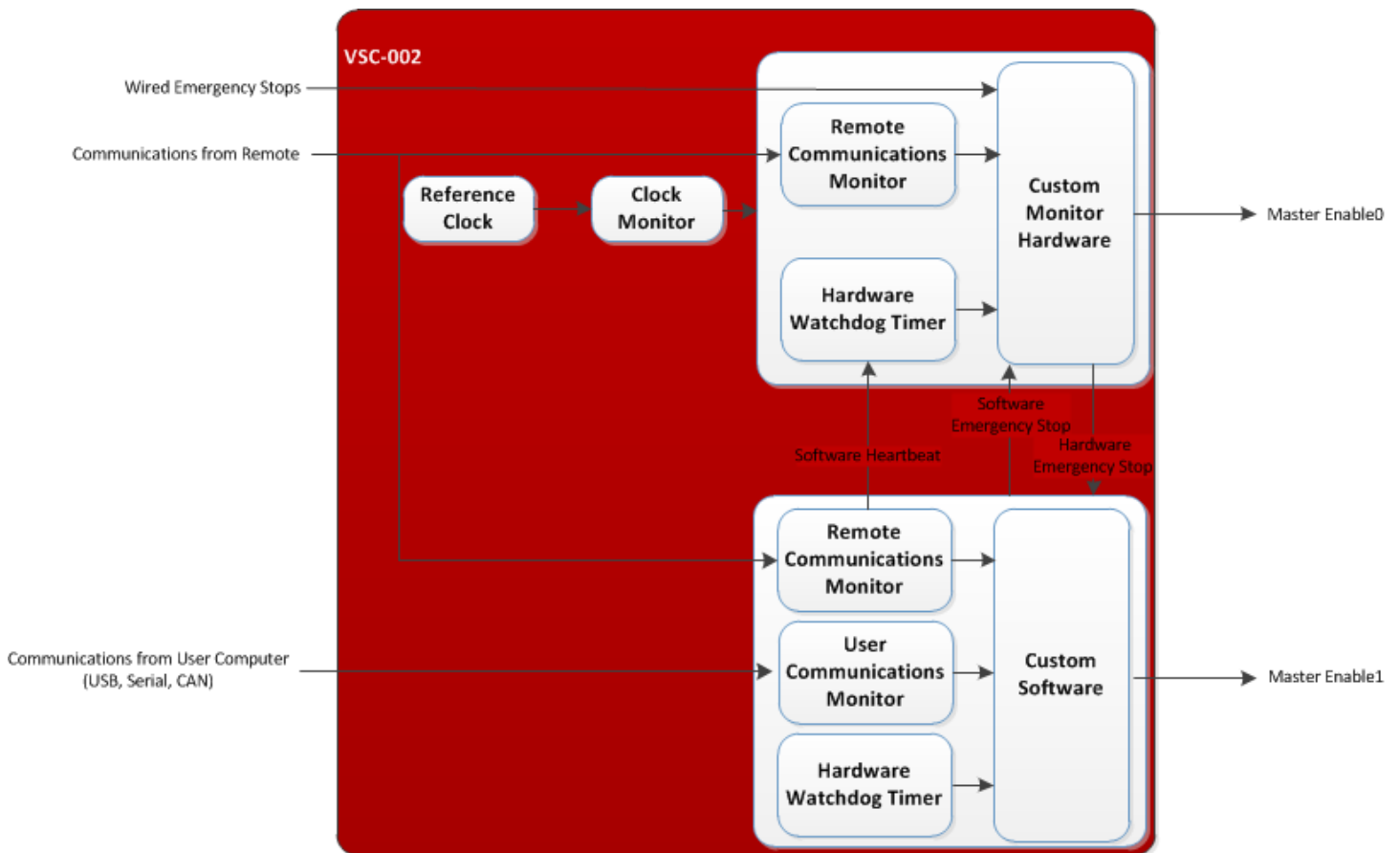

Figure 1 - Internal Hardware Monitors

The figure above illustrates the internal structure of the VSC in the SRCS. It is designed from the ground up to ensure that no single point of failure (hardware or software) exists that could cause an unsafe condition to not be caught and indicated by the Master Enable. It is important that system designers pay careful attention in the integration of the VSC with their drive system to ensure that motion will be prevented when the SRCS de-asserts the Master Enable signals.

4. Specifications (Vehicle Safety Controller – VSC)

The Vehicle Safety Controller (VSC-002) is an advanced receiver for FORT’s Safe Remote Control System (SRCS) and is designed to pair with FORT’s Safe Remote Control (SRC). It incorporates many of the SafetySense™ technologies described above.

4.1. Specifications

Parameter	Minimum	Typical	Maximum	Unit
Operating Temperature	-20		+60	°C
PVin High Operating Voltage	8	12	28	V
RF Transmit Power – 900MHz			140	mW
RF Transmit Power – 2.4GHz			100	mW
RF Receive Sensitivity	-101			dBm
RF Spread Spectrum		FHSS		
Data Security		AES 128		optional
Estop input voltage		PVin		V
Ingress Protection	IP66			
Weight		1.0		lbs
Radio Connector		RP-SMA		
Data Connector		Mini-CPC 4p (TE part # 1445421-1)		
I/O Connector		Mini-CPC 9p (TE part # 1445816-1)		

Table 1 - Vehicle Safety Controller Specifications

4.2. Data Interfaces

The VSC’s integration interface is USB, RS232, or CAN. The communication specifications (data rates and protocol) are described in the SRCS User’s Manual. The dual Master Enable outputs should be used to prevent any motion of the system under control when the VSC receives an emergency stop from either the SRC or its wired emergency stop input. The Master Enable outputs are open drain type, designed to drive the coil of a pair of safety relays. The emergency stop inputs are relative to the PVin . A single ground reference should be maintained for all power and reverence voltages.

Parameter	Minimum	Typical	Maximum	Unit
Master Enable V _{oi}	GND	0.1	0.7	V
Master Enable I _o			150	mA
Estop V _{ih}			PVin/2 + 6%	V
Estop V _{il}	PVin/2 - 6%			V

Table 2 - VSC Data Interface Specifications

4.3. I/O Connector Pinout

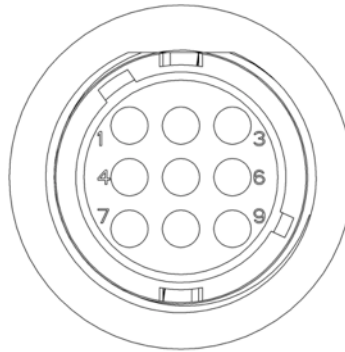
Figure 2 - VSC-002 I/O connector pinout

Pin	Signal Name	Type	VIC-001 Wire Color	Description
1	Master Enable 1	O	Blue	Normally low system enable output de-asserted = open = active estop condition asserted = closed (pulled low) = no estop condition
2	Estop_In_H	I	Brown	Normally low Estop input (high = active estop condition). Must be referenced to Vref voltage
3	Estop_In_L	I	Violet	Normally High Estop input (low = active estop condition). Must be referenced to Vref voltage
4	PVin	NA	Red	Power input
5	GND	NA	Green	
6	NA	NA	Grey	Reserved. Do Not Connect.
7	CAN_P/RS-232 TX	I/O	Yellow	CAN positive/RS-232 data interface transmit (depending on configuration)
8	CAN_N/RS-232 RX	I/O	Orange	CAN negative/RS-232 data interface receive (depending on configuration)
9	Master Enable 2	O	White	Normally low system enable output de-asserted = open = active estop condition asserted = closed (pulled low) = no estop condition

Table 3 - I/O connector pinout and signal descriptions

4.4. USB Connector Pinout

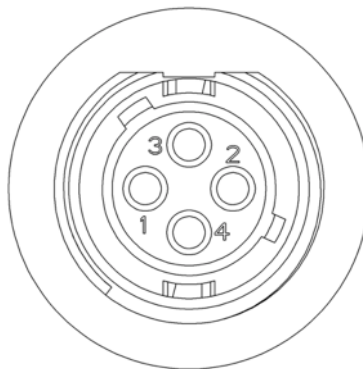
Figure 3 - VSC-002 USB connector pin location

Pin	Signal Name	Type	Description
1	USB D-	I/O	USB data negative differential signal
2	+5V	Vcc	USB power input
3	USB D+	I/O	USB data positive differential signal
4	GND	Vss	USB ground

Table 4 - VSC-002 USB connector pinout and signal descriptions

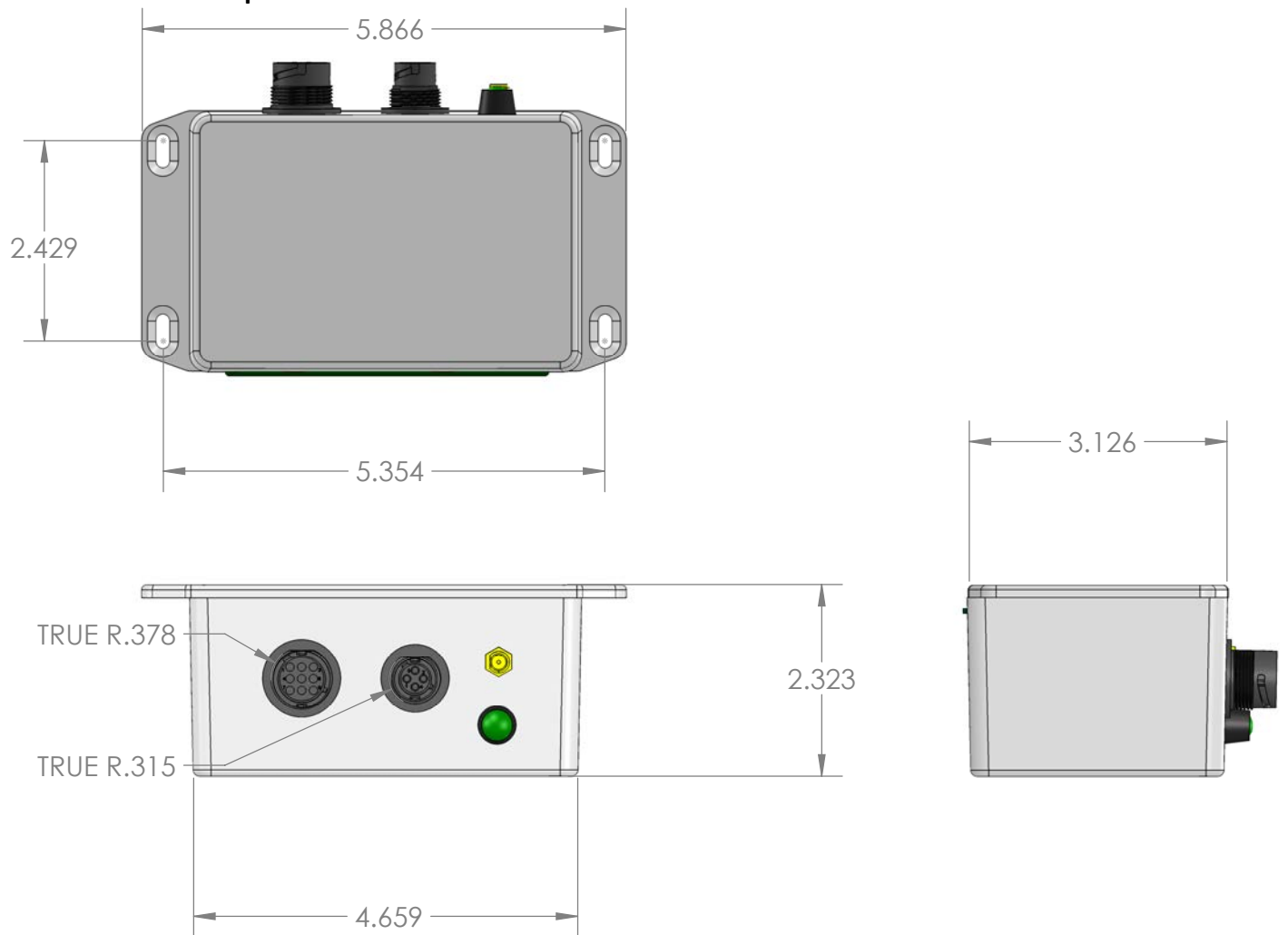
4.5. Mechanical Specification**Figure 4: VSC Mechanical Drawing**

5. Installation

5.1. Hardware Integration

A typical installation of the VSC-002 will use the supplied VIC-001 integration cable. This cable provides the connections required for most integration into systems with a user computer, wired emergency stops, and utilizing the Master Enable. The figure below illustrates the connections in a typical system.

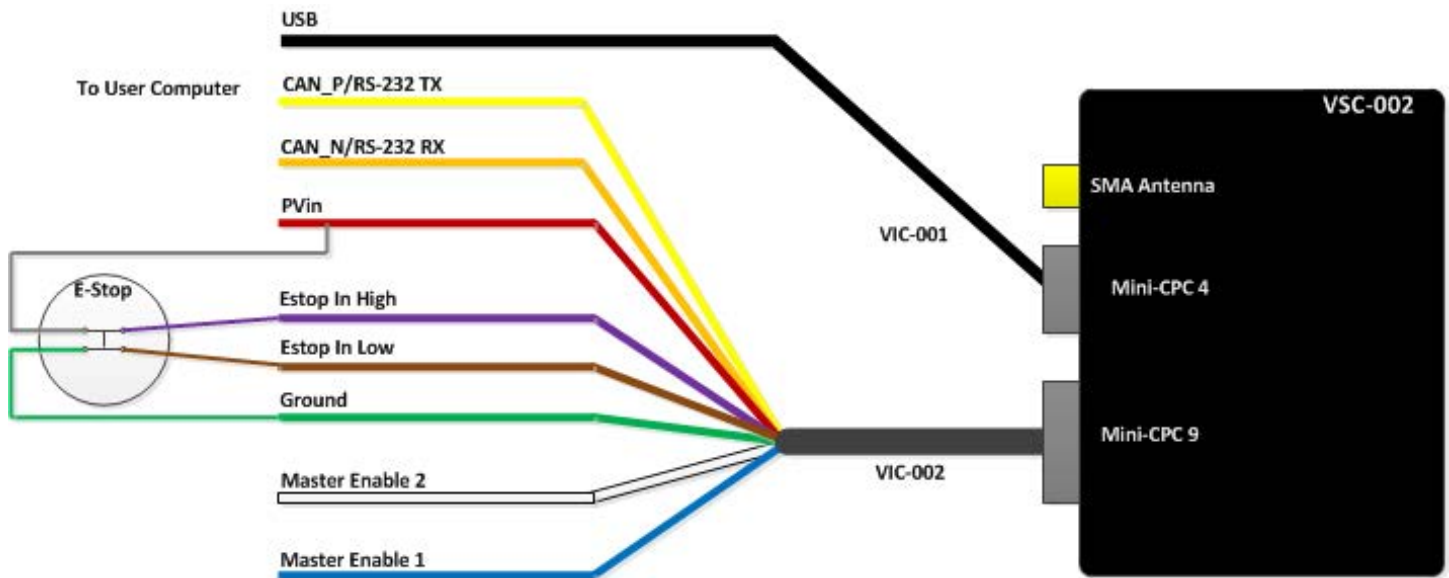

Figure 5 - Typical VSC-002 Connections

Estop_In_H and Estop_In_L are intended to be connected as shown through a standard emergency stop switch. These signals are internally biased to their fault state, so it is necessary to select a normally closed emergency stop button to short them as shown above in the system's normally operating condition. It is critical that the Estop_In_H and Estop_In_L signals are treated properly. The one or both of these signals are treated improperly or left unconnected; the VSC-002 will treat this as a fault condition and de-assert the Master Enable signals.

The Master Enable signals are open drain signals designed to drive either a digital enable inputs to the users drive system or a pair of safety relays to control the vehicle drive system. Examples of these two configurations are shown below.

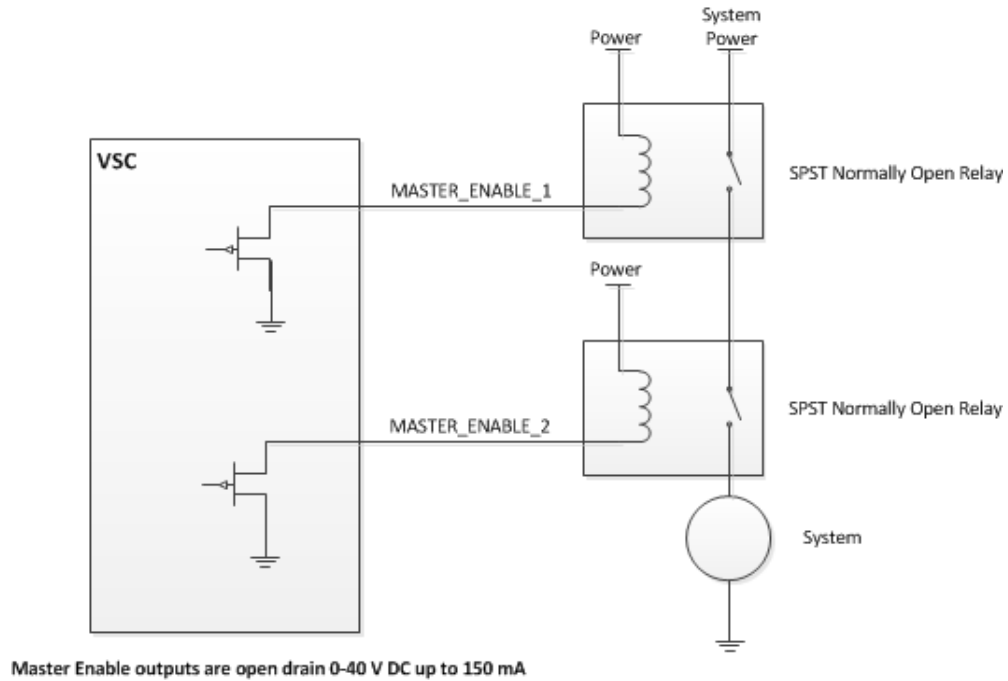

Figure 6 - Master Enable Relay Connection

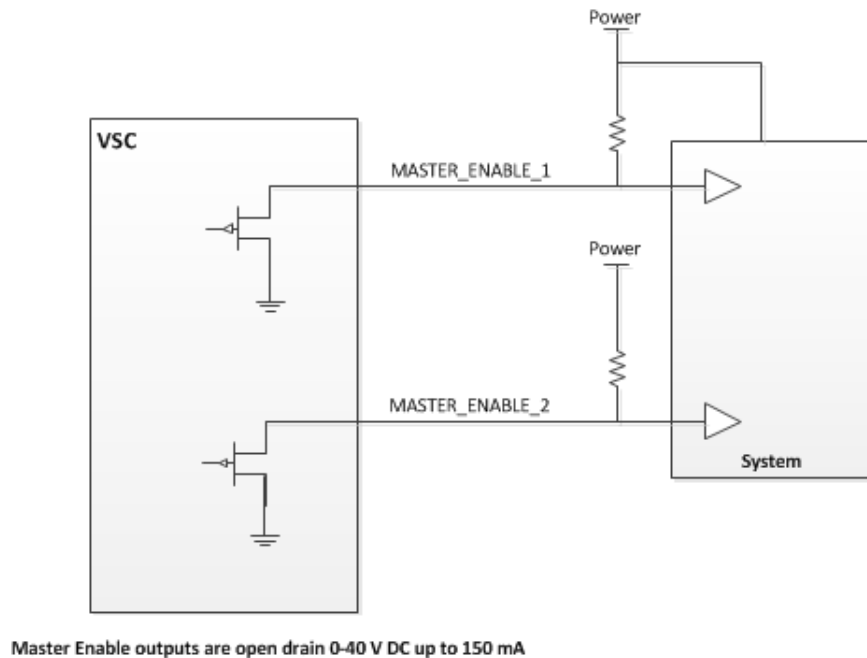

Figure 7 - Master Enable Digital Connection

5.2. Interfacing (RS232 / USB)

When using an RS232 or USB version of the VSC, all command and control communication is in the FORT Packet Protocol. The VSC USB interface is implemented as a CDC device and on most operating systems it will show up as a serial port (`/dev/tty.usbserial`, `/dev/ttyACM0`, etc). There are no differences in software integration when using the RS232 connection or the USB connection. An example C application is provided

that uses the FORT Packet Protocol to communicate with the VSC over a serial device. The example shows to how provide heartbeat and feedback messages to the VSC while receiving joystick, heartbeat and GPS messages from the VSC. Detailed integration information is described in the SRCS User's Manual.

5.3. Interfacing (CAN-J1939)

When using the CAN version of the VSC, all command and control communication is over the CAN Bus interface using J1939 Protocol. The VSC uses the SAE J1939 basic joystick messages and extended joystick messages to transfer information about the measured status of the X, Y and Z-axis of the joysticks, and the state of buttons. The SRCS uses custom SAE J1939 messages to transfer the heartbeat and key-value pair information. Detailed integration information is described in the SRCS User's Manual.

6. Ordering Information

Part Number	Description
VSC-002-(F)-(I)	Vehicle Safety Controller implementation kit with USB cable and 36-inch pigtail I/O connector (F) = Radio Selection 900: 900MHz FHSS AES128 140mW (inquire for higher power) 240: 2.4GHz FHSS AES128 100mW (inquire for higher power) ** Inquire about other frequency bands (I) = Interface Selection USB, UART, CANJ1939
VSC-003-(F)-(I)	Vehicle Safety Controller OEM kit: board and radio only, no enclosure or cables (F) = Radio Selection 900: 900MHz FHSS AES128 140mW (inquire for higher power) 240: 2.4GHz FHSS AES128 100mW (inquire for higher power) ** Inquire about other frequency bands (I) = Interface Selection USB, UART, CANJ1939
VIC-001	USB interface cable for VSC-002
VIC-002	36 inch pigtail I/O connector for VSC-002

Table 5 - VSC Orderable Part Numbers

7. Limited Warranty

All products sold by Humanistic Robotics, Inc are subject to the warranty provisions of the Humanistic Robotics Order Confirmation terms and conditions and are warranted against defects in material and workmanship for a period of one (1) year from the date of shipment. If you believe any Humanistic Robotics, Inc product you have purchased has a defect in material or workmanship or has failed during normal use within the warranty period, please contact Humanistic Robotics, Inc for assistance. If product repair or replacement is necessary, the Customer will be solely responsible for all shipping charges, freight, insurance and proper packaging to prevent breakage in transit, whether or not the product is covered by this warranty.

This warranty does not apply to defects resulting from any Customer actions, such as mishandling, improper interfacing, operation outside of design limits, misapplication, improper repair, or unauthorized modification. No other warranties are expressed or implied. Humanistic Robotics, Inc specifically disclaims any implied warranties of merchantability or fitness for a specific purpose and all warranties arising from course of dealing and/or trade usage. Humanistic Robotics, Inc.'s liability shall be limited to the actual purchase price of any defective unit or units of equipment to which a claim is made, and shall in no event include the Customer's manufacturing costs, lost profits or goodwill, or any other direct, indirect, special, incidental, consequential or punitive damages whether based on contract, tort or other legal theory. Humanistic Robotics, Inc shall not be liable for normal manufacturing defects or customary variances from specifications.

Products sold by Humanistic Robotics, Inc are not designed, intended or authorized for use in applications intended to sustain or support life, in any nuclear facilities or any other application where the failure of the product could create a situation where catastrophic property damage, personal injury or death may occur. In the event that the Customer purchases or uses any Humanistic Robotics, Inc products for any such unintended or unauthorized application, the Customer shall indemnify and hold harmless Humanistic Robotics, Inc and its officers, directors, employees, agents, affiliates, successors and assigns against all claims, costs, damages and expenses (including reasonable attorneys' and expert witness' fees) arising out of or in connection with, directly or indirectly, any claim for property damage, personal injury or death associated with such unintended or unauthorized use, even if such claim alleges that Humanistic Robotics, Inc was negligent regarding the design or manufacture of the subject product.

8. Revision History

Version	Date	Changes
-01	4/10/14	Initial Release